



INSTALLATION, OPERATION &

MAINTENANCE MANUAL

OF



Chilled/Heating Water Buffer Tanks

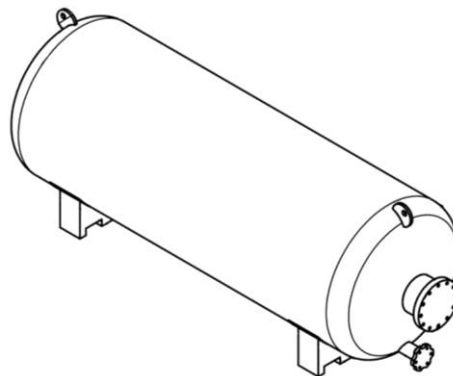
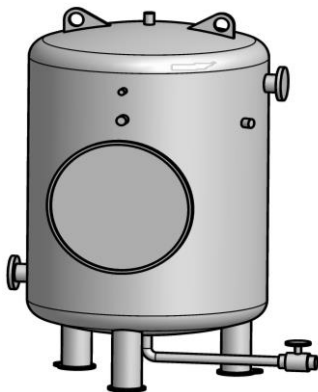

MASTERFLOW SOLUTIONS
HQ TEL: +61 2 9748 2022
WEBSITE: www.masterflow.net.au

GENERAL STATEMENT

Masterflow Solutions

Head Office
184 Newton Road
Wetherill Park, NSW, 2164
Australia

Dear Owner,

Congratulations on your purchase of AQUAZONE Buffer/Thermal Tank/s. Where applicable, AQUAZONE Buffer Tanks are designed and manufactured in accordance with AS1210 Pressure Vessel Code and/or AS1692-2006. The following details outline the minimum required for the installation and safe operation of your tank/s.

There are some helpful videos that will also assist you, available at www.masterflow.net.au

Maintenance is imperative to ensure maximum life span, and we encourage you to utilize the maintenance schedule which is available at www.masterflow.net.au

If there are questions not answered by this manual, or if specific installation, operation, and/or maintenance procedures are not clearly understood, contact your local representative before proceeding. Contact details are available at <http://www.masterflow.net.au/contact-us>

Yours Sincerely,

The Team at Masterflow Solutions

WARNINGS & PRECAUTIONS

The following warnings should be read and understood when handling and installing the tank/s:

**WARNING
OPERATION MAY CAUSE INJURY.
TAKE ALL NECESSARY PRECAUTIONS.
WEAR PROTECTIVE EQUIPMENT.
REFER TO ENGINEERS DEPARTMENT.**

DELIVERY & UNLOADING

- Unloading of the tank from the delivery vehicle remains the sole responsibility of the unloader. Due diligence and care must be exercised by qualified personnel, to ensure there is no damage to the tank, vehicle or surrounding property & personnel during unloading.
- Disposal of all packaging and any support frame is the responsibility of the Customer. Care must be taken when disassembling the timber packaging.
- The support frame if supplied, is designed for transport purposes only and must NOT be used for lifting other than forklifting off the delivery vehicle. That is, the support frame/cradle and its lifting lugs must NOT be vertically lifted by crane or similar.
- Unloading of the tank and rigging into its designated location must be done by qualified personnel. Masterflow takes no responsibility for any damage to the tank, surrounding property or personnel at and from the point of unloading from delivery vehicle.
- In some instances, the cover for the Inspection Opening may protrude and can be easily damaged during rigging. We recommend this be removed prior to rigging, done simply by undoing the latches that hold it on the tank.
- The tank shall not be subjected to any impact.
- Ensure sufficiently rated slings or chains are used and no damage is done to the tank during lifting. Lifting lugs on the tank have been engineered for lifting appropriately and evenly, by crane.
- Care should be taken to prevent any damage to the paint work or external insulation & cladding on the tank. All craneage and lifting is the responsibility of the customer. Expert advice should be sought prior to lifting.
- Nuts & Bolts may become loose during transit. Please ensure these are all checked and tightened where necessary, prior to lifting.

INSTALLATION

- Unless specifically ordered for outside, positioning of the tank must be indoors.
- The foundation base must be level and adequate to support the unit during operation. An engineered concrete slab or steel platform is acceptable.
- It is recommended the tank is installed on ribbed rubber matting of sufficient operational-load bearing capacity, as supplied by Masterflow Solutions.
- For tanks ordered specifically with inspection covers, please ensure there is sufficient room to gain access to the opening. There must not be any external forces imposed on the tank.
- Pipework connected to the tank must be self-supported to prevent unnecessary strain on the buffer tank connections.
- Isolation valves are to be installed to enable servicing and maintenance.
- Ensure adequate venting for air removal during filling and operation.
- Automatic Air Vents must be installed on the top port of the tank. **ONLY USE AUTOMATIC AIR VENTS WITH ½" CONNECTION SIZE.** For best performance and longevity, Masterflow recommends the large throat type such as the Optivent brand, Model OAAV15-HD – refer <http://www.masterflow.net.au/air-and-dirt-separators>
- For all bare or pre-insulated tanks, lifting lugs and tank legs to be insulated and sheathed by others on site.

COMMISSIONING & OPERATION

- Do not operate the buffer tank at pressures or temperatures in excess of those specified. Do not subject the tank to any vacuums. If there is potential for a vacuum situation, install a Vacuum Breaker device – refer to Masterflow for further details.
- If the tank is open vented and shares a common vent with other tanks, install a 3-way valve.
- Upon initial system fill open all isolation valves connected to the tank. Check all flanges and screwed joints for tightness.
- Ensure the tank is isolated from the system during any hydrostatic pressure testing. Tank must not be subjected to pressures higher than its Maximum Working Pressure.
- Ensure sufficient and correct water treatment to protect against internal corrosion.
- All liquid is to be drained from the tank when the unit is out of operation (for long periods) to prevent freezing or corrosion.

MAINTENANCE

1. Quarterly maintenance should include dumping a small amount of liquid by opening drain valve into container to sample. Check liquid for sludge. Before doing this close isolation valve upstream and downstream in buffer tank.
2. Masterflow recommends installation of its sacrificial anodes, preferably into the top of the tank. However, if there is insufficient room to insert these through the top of the tank, utilise any available ports on the side of the tank. These sacrificial anodes are designed to protect the tank, and shall be checked and replaced on a periodic basis. It is recommended these are checked monthly until it becomes apparent that the checks can be performed less regularly.
3. Ensure water treatment levels are maintained at a correct level and do not have any adverse impact on the materials of tank construction.
4. Where applicable, an annual maintenance check should include cleaning debris from the base of the tank (through the inspection opening) and visual inspection of tank internals.
5. Visually check tanks and inspect pressure gauge reading on a regular basis. Take a note of pressure gauge. Report any excessive readings. If greater than relief valve setting, check that relieve valve is functioning.
6. Refer to the Service Maintenance Register for a systematic recording of maintenance checks as outlined, at www.masterflow.net.au

WARRANTY

Products manufactured / distributed by MASTERFLOW SOLUTIONS are guaranteed to be free from defects in material and workmanship for one (1) year from the date of shipment.

The obligation under this warranty, statutory or otherwise, is limited to replacement or repair at the Masterflow factory, or at a point designated by MASTERFLOW SOLUTIONS, of such part as shall appear to us, upon inspection at such point, to have been defective in material or workmanship.

The warranty does not obligate MASTERFLOW SOLUTIONS to bear the cost of labour or transportation charges in connection with replacement or repair of defective parts; nor shall it apply to a product which repairs or alterations have been made unless authorized by MASTERFLOW SOLUTIONS in writing. In special cases where labour is covered under the issued warranty, it does not cover hard to access and hard to remove equipment. If rigging is required the associated costs will NOT be borne under this warranty. Masterflow will not be held responsible for poor plant room design.

No warranty is made in respect to electrical control panel, pumps, motors or trade accessories, such as being subject to warranties of their respective manufacturers.

No express, implied or statutory warranty, other than herein set forth is made or authorized to be made by MASTERFLOW SOLUTIONS.

In no event shall MASTERFLOW SOLUTIONS be liable for consequential damages or contingent liabilities arising out of the failure of any tanks/vessels/valves or parts thereof to operate properly.

Responsibility

The Manufacturer does not vouch for correct operation of the supplied product/s if they are tampered with or modified, run outside the recommended work range or in contrast with the other instructions given in this manual.

The Manufacturer declines all responsibility for possible errors in this instructions manual, if due to misprints or errors in copying. The company reserves the right to make any modifications to products that it may consider necessary or useful, without affecting the essential characteristics.

Modifications and Spare Parts

Any modification not authorized beforehand relieves the manufacturer of all responsibility. All the spare parts used in repairs must be original ones and the accessories must be approved by the manufacturer so as to be able to guarantee maximum safety of the machines and systems in which they may be fitted.